

SunTech® *Tango*®⁺

STRESS BP

User Guide



Table of Contents

Copyright Information	4
Safety and Effectiveness Considerations	5
Indications for Use.....	5
User Responsibility	5
Warnings and Contraindications	6
Tango+ Setup	7
Tango+ Hardware Setup.....	7
Rear Panel Connections	8
Tango+ Rear Panels	9
Power Supply Labels	10
Compatible Stress Systems	11
Stress System Setup.....	12
At a Glance	13
Front Display - Main Measurement View.....	13
Front Display - Graph View	15
Main Menu Selections and Settings	16
Monitor Setup	16
Measurement Setup	17
View	18
Alarms.....	19
Measurement Table	19
End Test.....	19
Proper Cuff Placement	20
Operation of Tango+	23
Taking a Blood Pressure Measurement	23
Headphone Kit.....	24
Stat Mode.....	24
Conducting an Exercise Stress Test	25
Accessories	27
Pulse Oximetry, SpO ₂ (optional).....	27
RS-232 & ECG Interface Cables.....	29
Maintenance and Cleaning	31
Advice & Troubleshooting	34
Status Messages	34
EMC Statement	38
Frequently Asked Questions (FAQ's).....	42
Service Centers	43
Specifications, Blood Pressure Measurement	44
Limited Warranty	46
Index	47

Copyright Information

All content in this manual is the proprietary information of *SunTech Medical* and is provided solely for purposes of operation, maintenance or service of *Tango+*. This manual and the *Tango+* described in it are protected under copyright law under which they may not be copied, in whole or in part, without written consent of *SunTech Medical*.

SunTech is a registered trademark of *SunTech Medical, Inc.* All other trademark names are the trademarks of their respective holders.

The information in this manual is furnished for guidance only, is subject to change without notice, and should not be construed as a commitment by *SunTech Medical*. *SunTech Medical* assumes no liability for errors or inaccuracies that may appear in this manual.

© 2008 *SunTech Medical*. All rights reserved.

Safety and Effectiveness Considerations



is a non-invasive multi-parameter monitor measuring blood pressure and oxygen saturation for use in cardiac or exercise stress testing. It measures and displays an adult patient's systolic and diastolic blood pressure and the percent oxygen saturation of arterial blood.

Indications for Use

Consider the following safety and effectiveness issues prior to using the *Tango+* Stress Test Blood Pressure Monitor:

- Use *Tango+* only with adult patients, while they undergo a cardiac or exercise stress test under the supervision of a physician. Ensure that appropriate resuscitation equipment and personnel are available at all times during the procedure.
- The *Tango+* BP monitor is defibrillator protected. The pulse oximeter is not defibrillator protected.
- All alarms indicate an increasing risk of injury if the test is continued.
- The reliability of the device depends upon conformance with the operation and service instructions, as detailed in this manual.

User Responsibility

Your *Tango+* is designed to perform in conformity with the description thereof contained in this operation manual and accompanying labels and inserts, when assembled, operated, maintained and repaired in accordance with the instructions provided. It is your responsibility to:

- Check calibration of this device annually.
- Never knowingly use a defective device.
- Immediately replace parts that are broken, worn, missing, incomplete, damaged or contaminated.
- Contact the nearest factory approved service center should repair or replacement become necessary. A list of approved service centers appears on page 42 or on our website at www.SunTechMed.com.
- The reliability of the device depends upon conformance with the operation and service instructions, as detailed in this manual.

Further, the user of the device bears sole responsibility for any malfunction that results from improper use, fault maintenance, improper repair, damage or alteration by anyone other than *SunTech Medical* or authorized service personnel.

Warnings and Contraindications

CAUTION: Federal (U.S.) law restricts this device to sale by or on the order of a physician.



DO NOT USE THE MONITOR IF it has failed its diagnostic self test or if it displays a greater than zero pressure with no cuff attached or a value of saturation with no sensor attached. The values displayed by such a unit

may be inaccurate.

DO NOT USE ON NEONATES, CHILDREN, and patients known to be readily susceptible to bruising.

DO NOT ATTACH THE CUFF to a limb being used for IV infusions as the cuff inflation can block the infusion, causing harm to the patient.

DO NOT ATTACH THE PULSE OXIMETER SENSOR to the same limb as the CUFF or any other blood flow restrictors. Loss of monitoring can occur due to the hindering of pulse measurements.

DO NOT USE IN THE PRESENCE OF FLAMMABLE anesthetics; this could cause an explosion.

DO NOT IMMERSE the monitor in any fluid, place fluids on top of, or attempt to clean the unit with any liquid detergents or cleaning agents. This may cause an electrical hazard. Refer to Maintenance & Cleaning for instructions on cleaning. If any of these situations occur, please contact *SunTech Medical*.

DO NOT REMOVE UNIT COVERS.

Doing so may expose hazardous voltage and cause electrical shock. The monitor does not contain any user serviceable components. Refer to Maintenance & Cleaning for service instructions.

DO NOT MAKE REPAIRS YOURSELF: No repair should be undertaken or attempted by anyone not having been service trained by *SunTech Medical* or having a thorough understanding of the repair and operation of automatic blood pressure equipment. (Substitution of a component different from that supplied might result in measurement error).

DO NOT allow the pulse oximeter sensor to become wet.

DO NOT use a damaged pulse oximeter sensor.

DO NOT CONNECT THE MONITOR TO EQUIPMENT THAT DOES NOT MEET EN60601-1. WHEN THE MONITOR IS ATTACHED TO A PATIENT, THE MONITOR'S RS-232 CONNECTOR CAN ONLY BE CONNECTED TO EQUIPMENT THAT MEETS EN60601-1.

PRECAUTIONS

Observe the patient carefully during the procedure. Ensure pressure compatibility to all patients. If any abnormality occurs, either in the unit or the patient, suspend the operation immediately and disconnect the cuff, pulse oximeter sensor, and electrodes (if applicable) from the patient.

Accuracy of any blood pressure recording or oxygen saturation measurement may be affected by the position of the subject, his or her physical condition and use outside of the operating instructions detailed in this manual. The interpretation of blood pressure and oxygen saturation measurements should only be made by a physician.

Safety and effectiveness in pregnant women, children under the age of 18 years of age and neonates have not been established.

Only use pulse oximeter sensors supplied by *SunTech Medical*.

Check the application site of the pulse oximeter sensor frequently to determine the positioning of the sensor and the circulation and skin sensitivity of the patient.

Factors that may affect the accuracy of pulse oximetry:

- electrosurgical interference
- arterial catheters, blood pressure cuffs, infusion lines, etc.
- moisture in the sensor
- improperly attached sensor
- incorrect sensor type
- poor pulse quality
- venous pulsations
- anemia or low hemoglobin concentrations
- cardiovascular dyes
- sensor not at heart level

Adverse Reactions

In the area of the cuff or sensor, allergic exanthema (symptomatic eruption) may result, including the formation of urticaria (allergic reaction including raised edematous patches of skin or mucous membrane and intense itching) caused by the fabric material of the cuff, sensor, or electrodes.

Following the application of the cuff, petechia (a minute reddish or purplish spot containing blood that appears in the skin) formation or Rumpel-Leede phenomenon (multiple petechia) on the arm, which may lead to idiopathic-thrombocytopenia (spontaneous persistent decrease in the number of platelets, associated with hemorrhagic conditions) or phlebitis (inflammation of a vein) may be observed.

Tango+ Setup

Tango+ Hardware Setup







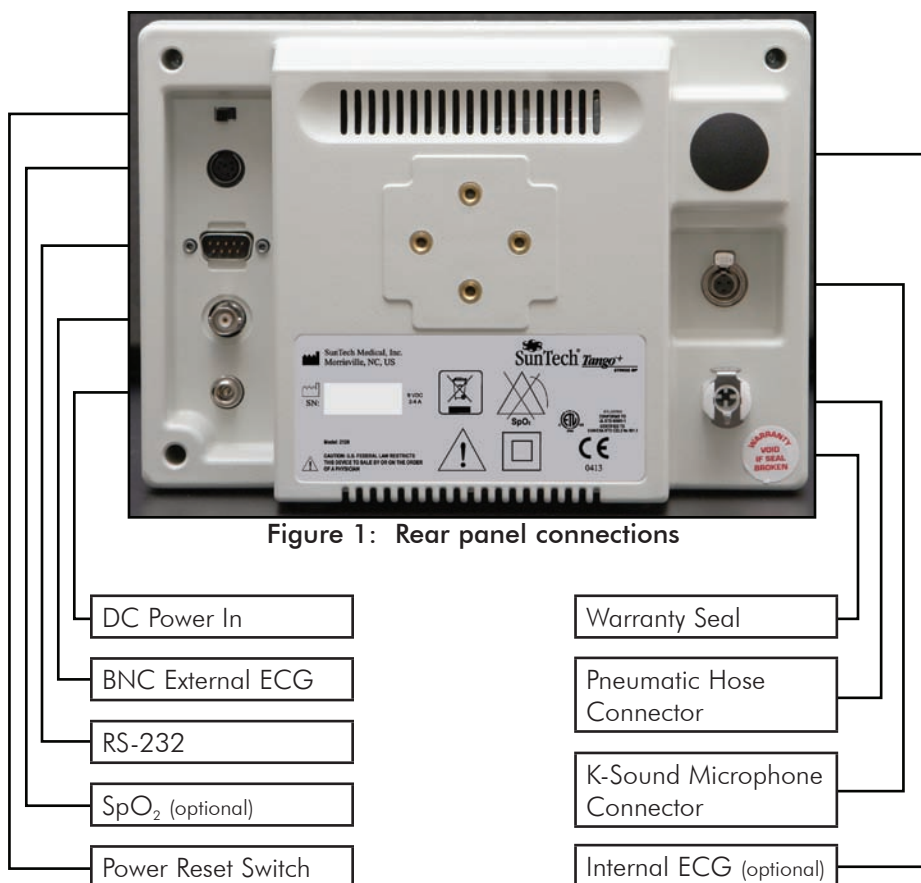

Your *Tango+* will come with a power supply, a patient cable, and an *Orbit-K* cuff(s) with a microphone.

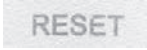
- Connect the power supply to a power cable and plug the cable into an available outlet.
- Connect the power supply (P/N 19-0012-00) to *Tango+* (See Figure 1). The monitor will turn on. If the monitor is attached to a stress system, the *Tango+* will turn on and off along with the stress system.
- Connect the patient cable (P/N 91-0001-00) to the K-sound Microphone and Pneumatic Hose Connector on the rear of the *Tango+* (See Figure 1).









If the *Tango+* has the Internal ECG option, the unit will come with an ECG patient cable (P/N 91-0004-00). Connect the ECG patient cable to the Internal ECG connection on the rear of the *Tango+* (See Figure 1).



Rear Panel Connections





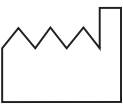





Connectors	Symbol	Description
Power Reset Switch		Resets the power on the monitor.
SpO ₂ Option		For measurement of oxygen saturation. Type BF Applied Part.
RS-232		Serial communication port for interfacing with stress systems or computers.
BNC External ECG		BNC/TTL port that allows a stress system to send an external analog or digital ECG trigger signal to the monitor.
DC Power In		9V DC input
Internal ECG Option		ECG patient cable connection. Defibrillator protected.
K-Sound Microphone		Connection for the patient's cable microphone cable. Defibrillator protected.
Pneumatic Hose		Connection for the patient cable's air hose. Defibrillator protected.
Headphone Kit		Located on the side of the unit next to the Power Reset switch (not pictured above)

Tango+ Rear Labels

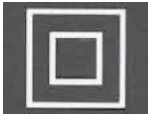
Label	Description
	ETL Certified
	Power supply contains materials which are hazardous. Must be disposed of properly.
	No SpO ₂ alarm
	Attention, consult accompanying documents.
	Class II isolation equipment.
	CE Approval
	Warranty Seal
	Manufactured By
	Manufacture Date

Power Supply Labels

External power supply (only use the *SunTech* power supply with *Tango+*). Input: 100-240 VAC @ 1.6A max, 50-60 Hz. Output +9VDC @ 5A

Label	Description
	Recognized component certified by UL to both Canada and U.S. requirements
	CE Mark
	TUV International Approval
	Attention
	Class II Isolation Equipment
	Earth Ground
	TUV Canada and United States Approval
	Power Supply contains material which are hazardous. Must be disposed of properly
	Output connection configuration - positive voltage; negative shield
	PSE Mark

Compatible Stress Systems

Tango+ can be setup to work directly with your stress system. If the *Tango+* is interfaced with a stress system, the stress system can prompt *Tango+* to take a BP measurement while you are conducting a stress test. In addition, some stress systems will transfer the blood pressure measurement and heart rate from *Tango+* to your stress system where it will be displayed on the screen and printed on any reports. The *Tango+* can be used as a stand alone only if the unit has the Internal ECG option.

The following stress systems are compatible with *Tango+*:

- AMEDTEC ECGpro
- Burdick Quest
- Cambridge Heart CH 2000/HearTwave II
- Delmar Reynolds CardioDirect with CardioCollect
- Esaote Formul@, Biosound Esaote Formul@ for Archimed
- GE CASE, CASE 8000
- GE CardioSoft
- Marquette CASE 12, 15, 16, Centra
- Marquette-Hellige CardioSys
- Marquette MAC 5000/5500
- Marquette MAC-VU-Stress
- Marquette/Sensormedics Max-1
- Medset Flashlight Ergo
- Midmark IQmark EZ Stress
- Mortara X-Scribe
- Nasiff Associates Cardio-Card
- Nihon Kohden ECG-9320A, 1550/1560
- Norav Stress ECG
- Oxford Medilog Stress
- Pulse Biomedical QRS-Card
- Philips StressVue
- Quinton Q-Stress, Q-5000, Q-4500, Q-4000, Q-3000, 710
- Schiller AT 10, AT 60, CS 200
- Sensormedics Vmax
- Viasys Encore Vmax
- Welch Allyn CardioPerfect

Stress System Setup

To setup the *Tango+* with your stress system, please visit the ***Tango+* Interface Notes** on the *SunTech Medical* website at www.SunTechMed.com. Select Customer Service ► Downloads and under the Products section, select *Tango+*. If your stress system is not listed, please contact:

+1.919.654.2300 (US)
+44(0)1865.884.234 (EMEA)
+852.2251.1949 (Asia & Pacific)

To test the stress system setup with *Tango+*, you will need to hook up a patient with ECG leads and take a blood pressure measurement. You cannot use a heart rate or blood pressure simulator to test whether the *Tango+* is working with your stress system. The *Tango+* monitor requires that the ECG signal and the Korotkoff sounds, collected by the microphone in the cuff, originate from the same source, meaning the patient.

DISCLAIMER: If the stress ECG system manufacturer modifies the communication protocol with the *Tango+* monitor without informing *SunTech Medical*, you may experience difficulties communicating with the stress system.

At a Glance

Front Display - Main Measurement View

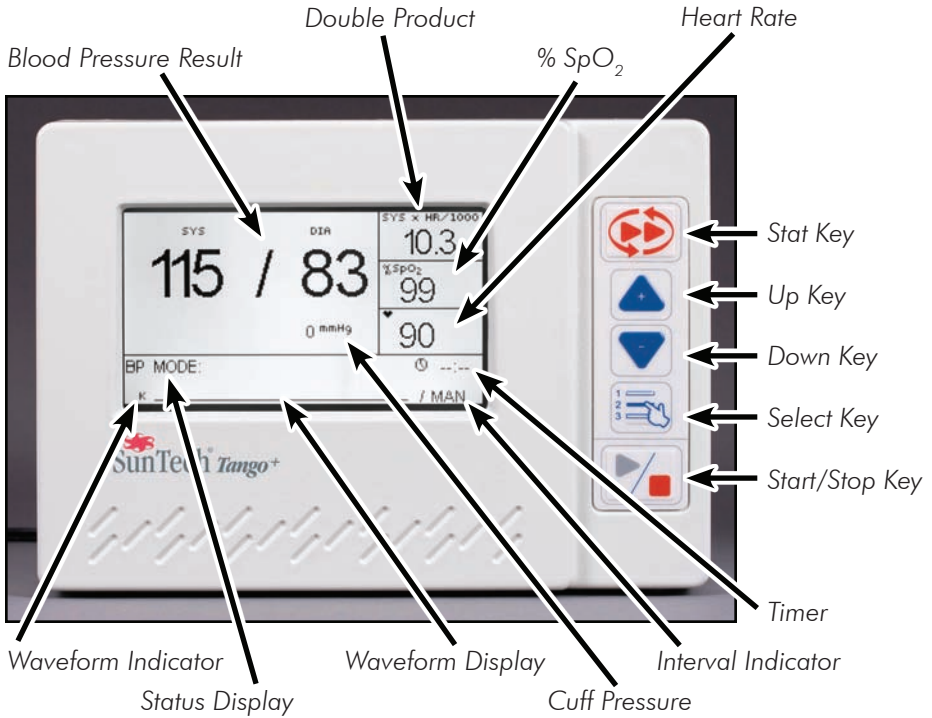

Figure 2: Front Display - Main Measurement View

Symbol	Function	Description
	STAT KEY	Starts or stops the Stat mode. (page 24)
	UP/DOWN	Helps you navigate through the screens.
	SELECT KEY	Selects measurement views of the data: Main Measurement View or Graph View. Also, lets you access the Main Menu Selection and settings. (page 16)
	START/STOP	Initiates a measurement or terminates one in progress. Also, lets you stop the Stat mode.

When the monitor is turned on, the Main Measurement View is displayed. This screen displays the following elements while you take a measurement:

- *Blood Pressure Result*: Displays latest or most current blood pressure.
- *Double Product*: Displays the current workload on the heart in mmHg beats per minute (SYS x HR/1000).
- *%SpO₂*: Displays the current percentage of oxygen saturation in arterial blood.
- *Heart Rate*: Displays current heart rate in beats per minute.
- *Waveform Display*: Displays either the K-sound or the ECG signal (see View ► Waveform Display on page 18)
- *Waveform Indicator*: Displays K for K-sound or E for ECG.
- *Status Display*: Displays current measurement mode, **BP** or **SYS** (see Measurement Setup ► Measurement Mode on page 17)
- *Interval Indicator*: Displays the interval mode the monitor is in (see Measurement Setup ► Interval on page 17)
- *Timer*: When Interval Indicator is set to **MAN**, displays how old the BP measurement is. When set to a time interval, the timer displays the time until next reading occurs.
- *Cuff Pressure*: Displays current pressure in the cuff.

Front Display - Graph View

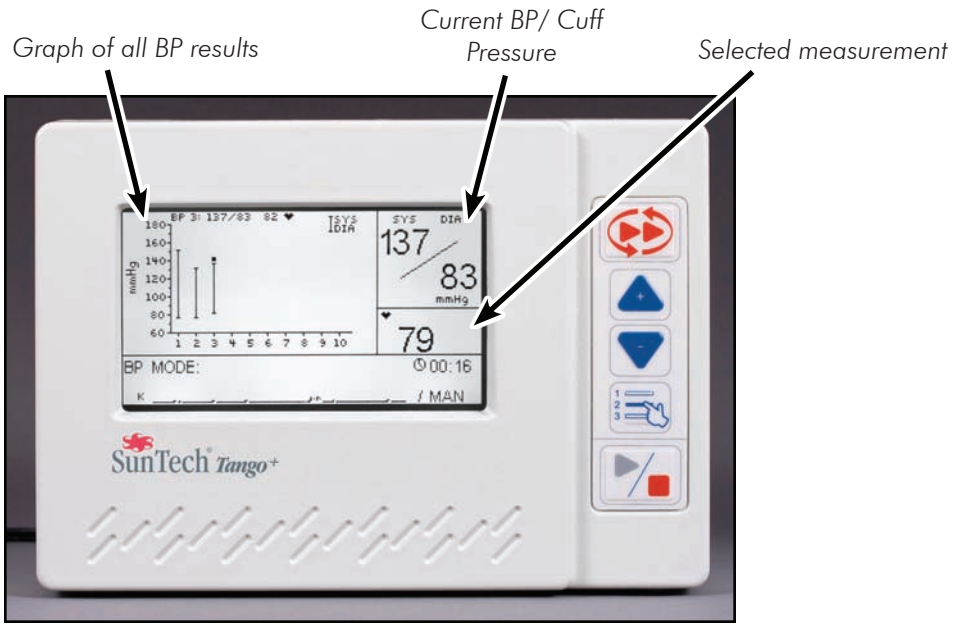

Figure 3: Front Display - Graph View

If you are on the Main Measurement View, pressing the **SELECT** key once will navigate to the Graph View. The Graph view displays the same information in the bottom section as the Main Measurement View. The top of the Graph View shows the following elements while you take a measurement:

- *Graph of all BP results:* Displays all blood pressure results in a study (up to 30 measurements). Use **UP/DOWN** buttons to navigate through the measurements.
- *Note:* Measurements with status messages will be omitted from the graph.
- *Current BP/Cuff Pressure:* Displays current blood pressure at the end of a measurement. Displays current pressure in the cuff during a measurement.
- *Selected Measurement:* Displays one of the following measurements: HR, %SpO₂, or Double Product (See View ► Graph Display on page 18).

Main Menu Selections and Settings

Press the Select key to access the **MAIN MENU**. Press the **UP/DOWN** keys to navigate through the **MAIN MENU** and then press the **SELECT** key to confirm your choice. To exit out of the **MAIN MENU**, select **EXIT** and you will return to the Main Measurement View.

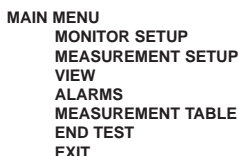

MAIN MENU
MONITOR SETUP
MEASUREMENT SETUP
VIEW
ALARMS
MEASUREMENT TABLE
END TEST
EXIT

Monitor Setup

Use to set up and maintain the monitor.

Stress System:	Select your stress system model that will interface to the <i>Tango+</i> . For a custom model, select CUSTOM and then choose the correct protocol and type of ECG trigger. If you are using the Internal ECG option, you must select CUSTOM and then set the ECG Trigger to INTERNAL .
Language:	Choose English, French, German, Italian, or Spanish
Time:	Set this to the current time. Defaults as 00:00.
Contrast:	Set monitor contrast for optimum display from 0–255 where 0 is darkest and 255 is lightest.
Verify Calibration:	Displays cuff pressure for verifying calibration of the monitor. Press the Select Key to quit.
Power Off After:	Set the time after which the monitor turns off after no activity. Set it to 10 minutes, 30 minutes, or Never . If <i>Tango+</i> is attached to a stress system, the <i>Tango+</i> turns on and off along with the stress system. However, you can turn the monitor on yourself by pressing any key. If you turn it on, the monitor will turn off after the time selected in this setting.
System Info:	Displays firmware version and internal serial board number of the <i>Tango+</i> .

Measurement Setup

Use to modify the blood pressure measurement settings.

Measurement Mode:	<p>Choose the monitor measurement: BP or SYS.</p> <p>BP includes both systolic and diastolic measurements and deflates at the specified deflate rate (see Deflate Rate below). SYS is a systolic measurement only and deflates at the AUTO deflate rate, resulting in faster measurement times.</p>
Interval:	<p>Set to MAN when interfacing a stress system with <i>Tango+</i>, so the stress system can prompt <i>Tango+</i> for a measurement. Also used if you want to initiate each measurement using the START/STOP key.</p> <p>Otherwise, select a time interval (in minutes) between BP measurements. The time intervals are 1:00, 1:30, 2:00, 2:30, 3:00, 4:00, 5:00, 10:00, or 20:00. If a specific time interval is chosen, you must press the START/STOP key for <i>Tango+</i> to take the first measurement. The <i>Tango+</i> will then automatically initiate BP measurements at the specified interval.</p>
Initial Inflate:	<p>Choose the pressure to which the cuff will inflate on the first measurement of a study. Select a setting from 120 to 280 mmHg (increments of 10).</p>
Max Inflate:	<p>Choose the maximum pressure allowed in the cuff during a measurement. Select a setting from 120 to 280 mmHg (increments of 10).</p>
Deflate Rate:	<p>Choose AUTO for normal deflation of the cuff pressure. Otherwise, enter a rate for special situations, such as standards testing. Enter a rate from 3 to 8 mmHg/sec.</p>
Beeper:	<p>Choose when the <i>Tango+</i> will make a sound indicating when the measurement is started or completed.</p> <p>BOTH: Beeps at the beginning and end of a measurement. NONE: The system will not beep. START: Beeps at the beginning of a measurement. FINISH: Beeps at the end of a measurement.</p>
Stat Mode Key:	<p>Choose the measurement made by the monitor when in Stat mode:</p> <p>BP: systolic and diastolic measurements SYS: systolic measurements only</p> <p>All measurements are made with the AUTO deflate rate.</p>

View

Use to modify the display settings.

Waveform Display:	<p>Choose the type of waveform that will be displayed:</p> <p>K-sound: This will display the Korotkoff sounds detected by the Orbit-K cuff microphone. Choose this for normal operation.</p> <p>ECG: Choose this when you are checking for a proper triggering signal.</p> <p>Note: ECG waveform is not for patient diagnosis. ECG waveform will automatically reset to the K-sound mode after 60 seconds.</p>
Graph Display:	<p>Choose the measurement you want to view in the Graph view: HR, DP, or SpO₂.</p>
BP Reset After:	<p>Set how long the last BP displays. Choose between (in minutes) 1, 2, 3, 5, 10 or select Never to always display the last BP.</p>
BP Shrink After:	<p>Set how long the last BP displays in a larger font. Choose between (in minutes) 1, 2, 3, 5, 10 or select Never to always display the larger font.</p>
New Patient:	<p>Set how the monitor prepares for a new patient:</p> <p>Auto: The system automatically prepares for a new patient.</p> <p>Prompt: The system will ask you if you have a new patient.</p> <p>To prepare the monitor for a new patient, <i>Tango+</i> will do the following:</p> <ul style="list-style-type: none"> • Set back to the Initial Inflate Pressure • The Main Measurement View will display “---” for all parameters until they are measured • The Graph View will not display any data points.
BP Pressure Units:	<p>Choose the units of measurement you want the BP measurements to be displayed in: mmHG or kPa</p>

Alarms

Alarms alert you to changes in blood pressure or heart rate. Alarms are only activated at the end of a BP measurement. An alarm of 5 beeps will sound along with a message in the status display. Alarms can be set for systolic blood pressure being too high (SYS HIGH) or too rapid of a decrease (SYS DROP), and for diastolic blood pressure or heart rate being too high, DIA HIGH or HR HIGH, respectively.

Sys High:	When the systolic BP exceeds this setting, the alarm sounds. Choose from 50 to 280 mmHg (with increments of 10) or set to Off.
Sys Drop:	When a drop in systolic BP between measurements exceeds this setting an alarm sounds. Choose from 10 to 100 mmHg (with increments of 5) or set to Off.
Dia High:	When the diastolic BP exceeds this setting, an alarm sounds. Choose from 20 to 150 mmHg (with increments of 10) or set to Off.
HR High:	When the heart rate exceeds this setting, an alarm sounds. Choose from 40 to 200 beats per minute (with increments of 10) or set to Off.

Measurement Table

The Measurement Table shows the most recent blood pressure measurements in a tabular format.

Up or Down:	Scrolls up or down the most recent 50 readings.
Select:	Exits table and gives you the option to clear all data from the table.

TIME	SYS	DIA	HR
12:00	120	80	65
11:57	120	80	65

End Test

Use this menu to clear readings and prepare for a new patient.

Yes:	Choose this to clear readings and prepare the monitor for a new patient.
No:	Keeps the readings and settings.

Proper Cuff Placement

To accurately measure blood pressure during a stress test, it is important that the *Orbit-K* cuff is the correct size and is placed correctly on the arm.

1. **Choose the appropriate *Orbit-K* cuff size.**
 - a. Without using the sleeve of the cuff, wrap the cuff around the patient's upper arm (Figure 4).



Figure 4: Sizing of cuff

- b. To verify the correct size cuff, make sure the **INDEX** falls within the cuff's **RANGE** arrow (located on the inside of the cuff). If the **INDEX** is outside the **RANGE** indicator, select a new cuff size. Caution: Remember that using a cuff that is the wrong size will result in false and misleading measurements.
2. **Place the *Orbit-K* cuff on the patient's arm.**
 - a. Palpate the brachial artery between the bicep and the tricep (Figure 5).

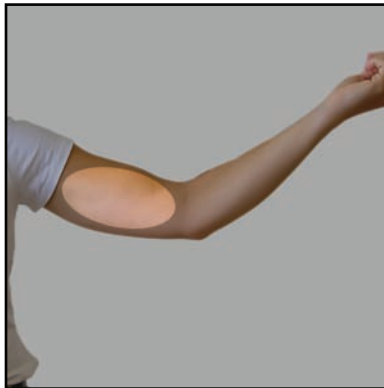

Figure 5: Location of brachial artery

- b. Slide the cuff sleeve up the patient's arm, ensuring the **ARTERY** marker points down the arm (Figure 6).



Figure 6: Sliding of cuff up the arm

- c. Place the **ARTERY** marker (which is where the microphone is located in the sleeve) over the brachial artery, about 3-5 cm above the elbow. The microphone should be on the medial part of the arm, not the top of the bicep (Figure 7).

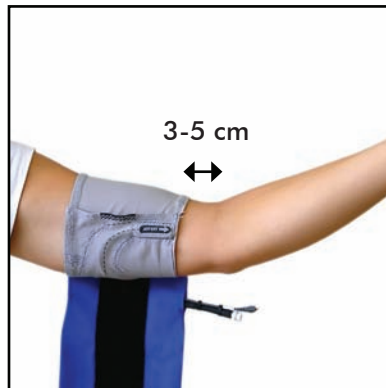

Figure 7: Proper placement of microphone

3. Wrap the cuff around the arm and secure (Figure 8). Use the wrist strap to secure the cables to the patient.



Figure 8: Wrapping of cuff around arm

Replacing the Microphone

When you receive the *Tango+* cuff, the microphone should already be properly inserted. If you need to replace the microphone, follow these simple steps:

1. Open the Velcro strap on the cuff and pull out the old microphone
2. Insert the new microphone through the sleeve, following the dash line, until the microphone is touching the bottom of the sleeve and is right under the **ARTERY** marker.
3. Connect the microphone to the bladder hose, using the rubber ties.
4. Close the Velcro flap over the cable.

***Note:** Annual replacement of the microphone is recommended.

Operation of Tango+

Taking a Blood Pressure Measurement

1. The Tango+ requires an ECG signal to take a measurement.

- For *Tango+* monitors that are interfaced with a stress system, ensure that your stress system's ECG connections are properly prepared and connect the electrodes to the patient.
- For *Tango+* monitors with the Internal ECG option, prepare and connect the 3 ECG electrode sites, RL, V2, and V6 to the patient (Figure 9).

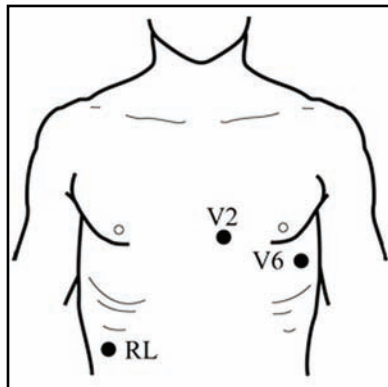

Figure 9: ECG Connections

- Ensure that each electrode is placed over a bony area and not over a large muscle mass which may cause excessive noise.
 - Prepare the skin at each electrode by shaving any body hair and cleaning the site thoroughly with alcohol.
 - For best results, the skin impedance should be less than 5 kohms as measured by a skin impedance meter.
 - Connect the ECG cable to the electrodes as follows:
 - Green lead to RL
 - Yellow lead to V2
 - Violet lead to V6
- #### 2. Place the Orbit-K cuff on the patient.
- Ensure the cuff is properly placed on the arm for reliable and accurate blood pressure measurements.
- #### 3. Ensure a stable heart rate is displayed on the monitor.
- A stable heart rate must be displayed on the monitor for *Tango+* to be able to obtain an accurate reading.
 - If no heart rate is displayed on the monitor, or the heart rate is erratic, consult the NO ECG DETECTED status message located in the Advice and Troubleshooting section of this manual (page 34).

4. Take a Blood Pressure Reading

- If the *Tango+* is interfaced to a stress system, prompt *Tango+* for a measurement via the stress system.
- If the *Tango+* has the Internal ECG option, prompt *Tango+* for a measurement by pressing the START/STOP on the monitor.

NOTE: During a stress test, some patients' K-sounds may continue to a very low pressure or, in some cases, all the way to 0 mmHg. This is due to increased arterial compliance, occurring as arteries dilate in response to exercise. When this occurs, there is usually a point where the K-sound amplitude drops off sharply, continuing at a reduced level. The pressure at which this sudden decrease in amplitude occurs will be reported as the first diastolic reading. If the K-sounds continue past that point for 10 mmHg or more, the second and final diastolic (diastolic tail) will be reported as the cuff pressure where the sound disappears. An example of how this is displayed is as follows:

BP = 180/93/58 mmHg

where "180" is systolic, "93" is first diastolic and "58" is the second diastolic (K-sound disappears). If the difference between the two diastolic points is less than 10 mmHg, only the first diastolic is displayed. If interfaced with a stress system, the *Tango* will report the BP result as the systolic and first diastolic blood pressure to the stress system.

Headphone Kit

- The headphone option of the *Tango+* will allow you to listen to the sounds that are picked up by the microphone in the cuff. These sounds are similar to those heard when taking a manual BP. Simply plug in the headphones to the phono jack on the *Tango+*.
- The headphone kit should only be used as an evaluation/reference tool. The headphones should not be used as a diagnostic tool.

Stat Mode

Tango+ has the ability to take continuous BP measurements for time sensitive or emergency situations by pressing the **STAT** key. The monitor will continue to take measurements every 2-10 seconds for up to 15 minutes or until the **STAT** or **START/STOP** key is pressed.

- Stat Mode will measure either a Systolic and Diastolic BP measurement or just Systolic BP measurement. Go to the Main Menu ► Measurement Setup ► Stat Mode Key to set the type of BP measurement to be taken in Stat Mode, **BP** (Systolic and Diastolic) or **SYS** (Systolic only).
- Full BP measurements can take as little as 30 seconds to display a measurement.
- Sys measurement can take as little as 15 seconds to display at measurement.
- The measurement displayed on the screen will flash to indicate that the monitor is in **STAT** mode. When the **STAT** mode is ended, the monitor will return to its previous mode.

Conducting an Exercise Stress Test

After your patient is properly prepared and a heart rate is displayed on *Tango+*, you are ready to conduct a stress test. Remember, you can stop a measurement in process by pressing the **START/STOP** button.

If your patient's condition becomes unstable, and you need to monitor their BP more closely, remember that you can place the monitor into Stat mode by pressing the **STAT** Key. You can stop a measurement and/or exit Stat mode by pressing the **STAT** or **START/STOP** button.

1. **Take 1–2 blood pressure measurements with the patient seated or standing still.**
 - a. With the patient sitting or standing still, take a measurement using your stress system or by pressing the **START/STOP** button.
 - b. As the measurement is being taken, watch the display for the cuff pressure and waveform display. With the waveform display showing K-sounds, you should see K-sounds just as you would hear them if taking a manual BP measurement with a stethoscope.
 - c. Once you take a reliable measurement with *Tango+*, you can proceed with the stress test. If, after two attempts, you are unable to get an accurate measurement with the *Tango+*, consult the manual for Advice and Troubleshooting tips (page 34).

2. Conduct the Stress Test.

- a. Advise and support your patient to get accurate BP measurements during the stress test. Make sure the patient's arm is relaxed while a BP is measured. Below are a few tips for keeping the arm relaxed during a stress test:
 - If the patient is holding onto the treadmill bar for support, advise the patient to lightly grip the bar. Alternatively, ask the patient to turn his/her hand over so that the palm is facing upward and resting on the treadmill bar.
 - Help your patient relax his/her arm when a measurement is taken (see Figure 10).

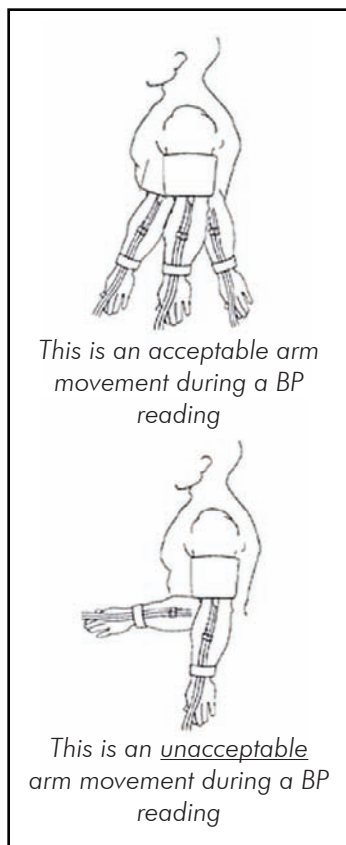

Figure 10: Limitations to arm movement during stress test

- b. As you take measurements with the *Tango+*, pay close attention to the status display and waveform display. If the status display shows a status message, consult the manual for Advice and Troubleshooting tips (page 34).

3. End Study.

- a. When the stress test is over and you no longer need to take blood pressures, press the **SELECT** key to display the main menu. Select **END TEST** and **YES** to clear the display of the last measurement and prepare the monitor for the next patient.
- b. If you have the New Patient setting (under Main Menu ► View ► New Patient; see page 18 for details) set to **AUTO**, *Tango+* will automatically prepare for a new patient once the ECG trigger signal is lost for 1 minute.

Accessories

Pulse Oximetry, SpO₂ (optional)

The *Tango+* is equipped with an option for pulse oximetry (P/N 98-0087-00). This option allows you to measure the oxygen saturation of arterial blood. Simply plug in the sensor/module cable to the SpO₂ receptacle on the rear panel of the *Tango+* and attach the sensor to your patient as described below. After a few seconds, a measurement will be displayed on the main measurement screen. The SpO₂ value is updated once per second. SpO₂ can also be displayed in the graph view. Go to Main menu ► View ► Graph Display and choose SpO₂. Please note the precautions that apply to pulse oximetry. You can replace the sensor by unplugging it from the module and plugging in the new sensor.

CAUTION: Patient sensitivity may vary due to medical status or skin condition. Discontinue use of adhesive tape strips if the patient exhibits an allergic reaction to the adhesive materials.

Preparing the Patient for Pulse Oximetry - Finger Application

CAUTION: Some nail polish colors (particularly dark shades) or artificial nails may reduce light transmission and affect pulse oximetry accuracy. Remove any nail polish or artificial nails before using the sensors.

To Attach the Adult Articulated Finger Clip Sensor:

1. Insert a finger (preferably the index, middle or ring finger) into the Adult Articulated Finger Clip Sensor (Figure 13) until the end of the finger reaches the finger stop. Keep the fingernail facing the sensor top. Ensure that long fingernails are not interfering with proper finger position.
2. For the best results when using the sensor for data collection, secure the sensor cable independently from the sensor with medical tape, preferably around the base of the fingers. Make sure that the tape securing the cable does not restrict the blood flow. The thumb is not recommended for use with the Adult Articulated Finger Clip Sensor.



Figure 13

Note: If the sensor is not positioned properly, light may pass the tissue and result in pulse oximetry inaccuracies. Proper sensor placement is critical for good performance.

Part Number	Description	Special Instructions
19-0012-00	Power Supply	
91-0001-00	Patient Cable, 15 ft	
91-0004-00	ECG Patient Cable	Required only for <i>Tango+</i> with internal ECG
98-0006-01	K-sound Microphone, 18"	
98-0062-03	Orbit-K Large Adult Cuff	Includes microphone, Range: 32-44cm
98-0062-05	Orbit-K Adult Plus Cuff	Includes microphone, Range: 27-40cm
98-0062-02	Orbit-K Adult Cuff	Includes microphone, Range: 25-35cm
98-0062-01	Orbit-K Small Adult Cuff	Includes microphone, Range: 18-27cm
36-0001-01	Pole/Rail Clamp w/ screws	
98-0003-00	Wrist Strap	
98-0030-00	T-tube Kit	For calibration check
98-0087-00	Xpod® SpO ₂ kit, Adult Finger Clip	Includes Xpod and Adult Finger Clip Sensor
91-0088-00	Xpod pulse oximeter	
52-0003-00	Purelight® Adult Finger Clip Sensor	
80-0001-06	User's manual	
80-0002-01	Service manual	
27-0054-B1	Tutorial CD	
99-0027-06	Additional One-year Warranty	Extended warranty – 1 year
99-0027-07	Second Year Added Warranty	Extended warranty – 1 year
99-0027-08	Third Year Added Warranty	Extended warranty – 1 year
99-0027-09	Three Year Extended Warranty	Extended warranty – 3 years (purchased at one time)
51-0000-00	Headphones	
91-0076-00	Extension cable for headphones	

RS-232 & ECG Interface Cables

Stress System	RS-232 Cable	ECG Trigger Cable
AMEDTEC ECGpro	91-0013-00	91-0066-00
Burdick Quest	91-0013-00	91-0011-00
Cambridge Heart CH 2000 & HearTwave II	91-0065-00 (RS-232 and ECG)	
Delmar Reynolds CardioDirect with CardioCollect	91-0013-00	91-0066-00
Esaote Formul@, Biosound Esaote Formul@ for Archimed	91-0048-00	Formula P/N 91-0049-00 Formul@ P/N 91-0072-00
GE CardioSoft	91-0013-00	91-0009-00
GE CASE	91-0013-00	91-0009-00
GE CASE 8000	91-0013-00	91-0009-00
Marquette CASE 12	91-0012-00	91-0011-00
Marquette CASE 15	91-0012-00	91-0011-00
Marquette CASE 16	91-0012-00	91-0011-00
Marquette Centra	91-0012-00 91-0013-00	91-0011-00
Marquette Mac 5000/5500	91-0010-00	91-0009-00
Marquette Mac-VU-Stress	91-0010-00	91-0014-00
Marquette/Sensormedics Max-1	91-0010-00	91-0009-00
Marquette-Hellige CardioSys	91-0013-00	91-0016-00
Medset Flashlight Ergo	91-0013-00	-----
Midmark Diagnostics IQmark EZ Stress	91-0013-00	91-0011-00
Mortara X-Scribe	91-0013-00	91-0011-00
Nasiff Associates Cardio-Card	91-0013-00	91-0018-00
Nihon-Kohden Cardiofax ECG-9320A	91-0061-00	91-0060-00
Nihon-Kohden Cardiofax 1550/1560	91-0061-00	91-0018-00
Norav Stress	91-0013-00	91-0011-00
Oxford Medilog Stress/PBI QRS Card	91-0013-00	Contact PBI or Oxford
Philips Stress Vue	91-0013-00	91-0011-00
Quinton Q3000/Q4000/710	-----	91-0018-00
Quinton Q4500	91-0013-00	91-0018-00

RS-232 & ECG Interface Cables

Stress System	RS-232 Cable	ECG Trigger Cable
Quinton Q5000	91-0020-00	91-0018-00
Quinton Q-Stress	91-0013-00	91-0018-00
Schiller AT10/AT60/CS-200	91-0035-00	91-0022-00
Welch Allyn CardioPerfect Workstation	91-0013-00	91-0018-00

Splitter Cables

Stress System	Part Number
GE CASE - use with echocardiograph	91-0053-00
GE CASE 8000 - use with echocardiograph	91-0053-00
Marquette/Sensormedics Max-1 - use with echocardiograph	91-0053-00
Marquette MAC 5000/5500 - required	91-0069-00

Maintenance and Cleaning

Preventative Maintenance

Establishing simple care guidelines helps protect the performance and life of your *Tango+*. On a routine basis, you should inspect the device, cables and pneumatic hoses for cracks, fraying or kinks and immediately replace any damaged parts.

The monitor performs a range of system and software checks during normal operation, reporting to the user the operational status via the Status Display. Once the monitor is on and the Main Measurement View is displayed, ensure that the monitor's status display indicates the correct measurement mode. Also, verify that the cuff pressure is 0 mmHg when no cuff is attached. **DO NOT** use the monitor if it has failed any of its diagnostic self tests or if it displays a greater than zero pressure with no cuff attached.

The monitor does not contain any user serviceable parts and should only be opened by an authorized service representative. **DO NOT** remove covers or break the warranty seal as this will void the manufacturer's warranty.

Calibration

It is recommended that the *Tango+* have its calibration checked annually to verify the accuracy of the pressure transducers and indicators.

Equipment Required:

1. Calibrated electronic manometer or equivalent.
2. 500mL volume or the Orbit-K Adult Plus cuff wrapped around something that will not break or crush (no glass).
3. Hand Inflation Bulb with bleed valve.
4. Tubing, Tee pieces, and miscellaneous connectors or you can order the T-Tube Kit (SunTech Part # 98-0030-00).

Procedure:

1. When the Main Measurement View is displayed, press the **SELECT** button 2 times. This will bring up the **MAIN MENU** screen.
2. Using the UP or DOWN arrows, highlight **MONITOR SET UP** and press the **SELECT** button.
3. Using the UP or DOWN arrows, highlight **VERIFY CALIBRATION** and press the **SELECT** button. The monitor will close its bleed valves and will display on its screen the pressure applied to the patient hose connector.
4. Verify the *Tango+* calibration by manually inflating and checking the manometer against the pressure reading on the *Tango+* display. The Display should be within ± 2 mmHg of the pressure value on the mercury manometer through a range of pressures from 0-300mmHg. If not, contact *SunTech Medical* about calibration.
5. Once the calibration has been completed, press the **SELECT** button to exit the calibration screen. Then press the UP or DOWN arrows to select **EXIT** twice and return to the Main Measurement View.

Disposal

This symbol indicates the monitor contains materials (such as electrical components) which are hazardous. Please return to *SunTech Medical* for disposal.

WARNING: Fire, explosion and severe burn hazard. The unit contains a lithium battery that must be disposed of properly or returned to *SunTech Medical* for disposal.



Pulse Oximeter

Cautions:

- Do not immerse the sensor in liquid.
- Do not use caustic or abrasive cleaning agents on the sensors.

Cleaning

Monitor

Before cleaning, disconnect the power supply from the monitor. Wipe the device with a soft, damp cloth to remove surface dust and dirt.

CAUTION: The *Tango+* is not sterilizable. Do not immerse the monitor in any fluid or attempt to clean with any liquid detergents, cleaning agents, or solvents.

Cuffs

Use a mild medical grade disinfectant on the cuff sleeve and inside of the cuff between patients. Periodically, remove the bladder, machine wash the shell of the cuff in cold water and line dry.

ECG Cables

For routine cleaning, use a soft cloth to apply a mild soap and water mixture. Remove any residue and wipe dry. For disinfecting the cables, use a hospital-approved disinfectant such as 1:10 chlorine bleach, Lysolbrand disinfectant, 2% glutaraldehyde solution, or Wescodyne. If disinfectants are intended to control infection, use your facility's established protocol. For sterilizing, use your facility's established protocol. Do not use the following methods for sterilization: autoclave, radiation, or steam. When necessary, cables and leads can be sterilized in ethylene oxide (ETO) gas.

SpO₂ Sensors

Clean the sensor with a soft cloth dampened with a mild detergent or isopropyl alcohol. Ensure that all tape residues are removed. Allow the sensor to dry thoroughly before reusing.

CAUTION: Never immerse sensors and clips in fluids. Do not pour or spray any liquids onto the sensor. Caustic or abrasive cleaners will cause permanent damage.

NOTE: Do not open the case of the adult finger clip sensor more than 90° or the case may be damaged. Figure 11 shows the appropriate opening of the case for cleaning.



Figure 11

Advice & Troubleshooting

Status Messages

If there is significant noise (as you may note on the Waveform Display) during a measurement, the *Tango+* will have problems getting a reliable measurement. Status messages appear over the Status Display in the Main Measurement view or the Graph View immediately after a reading to indicate that there was a problem during that measurement. Some errors will produce prompts that will appear over the BP measurement that provide suggestions to resolving an issue. Status messages inform you of the validity of a blood pressure reading. To avoid this problem with subsequent measurements, follow the appropriate solutions below.

Message	Description	Solution
AIR LEAK	The monitor will terminate a BP reading if the target inflation is not reached in 60 seconds.	<ul style="list-style-type: none"> • Check that the cuff or the patient cable is not leaking on inflation. • Check that the patient cable is properly connected to the monitor.
CHECK ECG	ECG signal is weak, erratic or missing for more than 3 seconds. No BP reported.	<p>Ensure that a heart rate is displayed on the <i>Tango+</i>. If so, try again.</p> <p>Set the Waveform Display (under View in the Main Menu) to ECG to verify the monitor is receiving an ECG Signal.</p> <ul style="list-style-type: none"> • If the signal is present, take another BP reading. If it fails to measure a BP, the patient may have ECG problems which prevent the <i>Tango+</i> from working properly. • If the signal is not present: • Check ECG lead connections are secure along the ECG patient cable and at the electrodes. • Ensure electrodes are correctly positioned, prepared and attached. • Review instructions for your stress system interface with the <i>Tango+</i>. (See <i>Tango+ Setup</i>, page 7). Check to see that your Stress System (if Custom, check the ECG Trigger) is correctly set. • Check that the cables referred to in the instructions are correctly seated to their connectors and show no signs of damage.

CHECK ECG/ MIC	Weak or missing K-Sounds and the ECG signal is erratic.	Review the solutions for CHECK ECG and CHECK MIC.
CHECK MIC	Weak, missing or no K-sounds detected. No BP reported.	<ul style="list-style-type: none"> • Check that the microphone is positioned over the brachial artery on the patient (see Proper Cuff Placement, page 20). • Check that the patient cable microphone and the connection to rear panel of the <i>Tango+</i> are secure. • Review instructions for your stress system interface with the <i>Tango+</i>. Check that the ECG trigger (under Main menu ► Monitor setup ► Stress System) is correctly set. • Check that the microphone is flat (not bent) and that its wire is securely connected. If they are not, the microphone needs to be replaced. • Test microphone by tapping the cuff and checking for a rising and falling signal on the Waveform Display. If there is no movement in the signal, the microphone needs to be replaced. • Replace microphone and cuff annually.
CUFF OVER-PRESSURE	The monitor will terminate a BP reading if the patient cable or BP cuff has reached an unreasonably high pressure. No BP reported.	<ul style="list-style-type: none"> • Instruct your patient to drop his arm by his side while a BP reading is in progress (avoid excessive bending of the arm). • Check that the patient cable is not being pinched or blocked.
EXCESSIVE ARM MOVEMENT	Excessive K-sound noise or arm movement. May result in no BP reading.	Instruct your patient to drop his/her arm by their side and relax their arm while the BP reading is in progress.

INFLATION TOO LOW	K-sounds were detected within 10mmHg of the target cuff inflation pressure. BP reported.	BP reading may be inaccurate. Advise the patient to drop arm to the side during the BP reading (avoid excessive bending). Take another BP reading. Note – Cuff will inflate to max pressure on next BP reading.
MEASUREMENT DELAYED	Due to safety reason, a BP measurement could not be taken at that time.	The next BP reading will occur as scheduled.
NO ECG DETECTED	The monitor is not receiving an ECG signal.	<ul style="list-style-type: none"> • Review instructions for your stress system interface with the <i>Tango+</i> (See <i>Tango+</i> Setup, page 7). Check to see that your Stress System (if Custom, check the ECG Trigger) is correctly set. • Check that the cables referred to in the instructions are correctly seated to their connectors and show no signs of damage. • Set the Waveform Display (under View in the Main Menu) to ECG to verify the monitor is receiving an ECG Signal.
REPEAT BP	The BP measurement needs to be repeated.	Initiate a new BP reading via the Stress System or the <i>Tango+</i> START/STOP key.
SERVICE REQUIRED	N/A	Contact your nearest <i>SunTech Medical</i> Service Department or authorized service agent. The unit must be sent to <i>SunTech Medical</i> for repair.
SYS > 280 mmHg (37.3 kPa)	Systolic reading is above 280 mmHg (37.3 kPa).	Therefore, dashed lines will appear for that systolic reading.
SYS < 50 mmHg (6.7 kPa)	The systolic reading is below 50 mmHg (6.7 kPa).	Therefore, dashed lines will appear for that systolic reading.
DIA > 150 mmHg (20.0 kPa)	The diastolic reading is above 150 mmHg (20.0 kPa).	Therefore, dashed lines will appear for that diastolic reading.

DIA < 20 mmHg (2.7 kPa):	The diastolic reading is below 20 mmHg (2.7 kPa).	Therefore, dashed lines will appear for that diastolic reading.
HR > 200	Heart rate is above 200 bpm.	Therefore, the reading can not be displayed. (Note – this will be displayed in the heart rate box when the heart rate is out of range).
HR < 40	Heart rate is below 40 bpm.	Therefore, the reading can not be displayed. (Note – this will be displayed in the heart rate box when the heart rate is out of range).
BP > 280/150 mmHg (37.3/20.0 kPa)	BP reading (both the systolic and diastolic readings) are above 280/160 mmHg (37.3/20.0 kPa).	Therefore, dashed lines will appear for both readings.
BP < 50/20 mmHg (6.7/2.7 kPa)	BP reading (both the systolic and diastolic readings) are below 50/20 mmHg or (6.7/2.7 kPa).	Therefore, dashed lines will appear for both readings.

SYSTEM ERRORS: A System Error (monitor displays a System Error screen with a 5-digit error code) indicates a possible problem with the monitor's hardware or software. When this error occurs, the alarm will sound continuously. This alarm can be muted by pressing the Down key. Pressing the Select key will clear the alarm, and the monitor will rerun its internal tests. If the error occurs repeatedly, please contact the SunTech Service Department or an authorized service agent.

To test the System Error alarm function, press the Up key when power is applied to the monitor. System Error "30000" should appear on the screen. Pressing the Down key will mute the alarm. Pressing the Select key will end the test; the monitor will complete its power-up sequence and display the Main Measurement View.

EMC Statement

This equipment has been tested and found to comply with the limits for medical devices to IEC60601-1-2: 2001. These limits are designed to provide reasonable protection against harmful interference in a typical medical installation. This equipment generates, uses and can radiate radio frequency energy and, if not installed and used in accordance with the instructions, may cause harmful interference to other devices in the vicinity. However, there is no guarantee that interference will not occur in a particular installation. If this equipment does cause harmful interference to other devices, which can be determined by turning the equipment off and on, the user is encouraged to try to correct the interference by one or more of the following measures:

- Reorient or relocate the receiving device.
- Increase the separation between the equipment.
- Connect the equipment into an outlet on a circuit different from that to which the other device(s) are connected.
- Consult the manufacturer or field service technician for help.

Portable and mobile RF communications equipment can affect Medical Electrical Equipment. Use of accessories, transducers, and cables other than those specified may result in increased emissions or decreased immunity of the *Tango+*. The *Tango+* should not be used adjacent to or stacked with other equipment. If adjacent or stacked use is necessary, the *Tango+* should be observed to verify normal operation in the configuration in which it will be used.

Guidance and manufacturer's declaration – electromagnetic emissions		
The <i>Tango+</i> Monitor is intended for use in the electromagnetic environment specified below. The customer or the user of the <i>Tango+</i> Monitor should assure that it is used in such an environment.		
Emissions test	Compliance	Electromagnetic environment – guidance
RF emissions CISPR 11	Group 1	The <i>Tango+</i> Monitor uses RF energy only for its internal function. Therefore, its RF emissions are very low and are not likely to cause any interference in nearby electronic equipment.
	Class B	
Harmonic emissions IEC 61000-3-2	Class A	The <i>Tango+</i> Monitor is suitable for use in all establishments, including domestic establishments and those directly connected to the public low-voltage power supply network that supplies buildings used for domestic purposes.
Voltage fluctuations/ flicker emissions IEC 61000-3-3	Complies	

Guidance and manufacturer's declaration – electromagnetic emissions

The *Tango+* Monitor is intended for use in the electromagnetic environment specified below. The customer or the user of the *Tango+* Monitor should assure that it is used in such an environment.

Immunity test	IEC 60601 test level	Compliance level	Electromagnetic environment-guidance
Electrostatic discharge (ESD) IEC 61000-4-2	± 6 kV contact ± 8 kV air		Floors should be wood, concrete or ceramic tile. If floors are covered with synthetic material, the relative humidity should be at least 30 %.
Electrical fast transient/burst IEC 61000-4-4	± 2 kV for power supply lines ± 1 kV for input/output lines		Mains power quality should be that of a typical commercial or hospital environment.
Surge IEC 61000-4-5	± 1 kV differential mode ± 2 kV common mode		
Voltage dips, short interruptions and voltage variations on power supply input lines IEC 61000-4-1	$< 5\% U_T$ ($> 95\%$ dip in U_T) for 0,5 cycle $40\% U_T$ (60 % dip in U_T) for 5 cycles $70\% U_T$ (30 % dip in U_T) for 25 cycles $< 5\% U_T$ ($> 95\%$ dip in U_T) for 5 sec		Mains power quality should be that of a typical commercial or hospital environment. If the user of the <i>Tango+</i> Monitor requires continued operation during power mains interruptions, it is recommended that the <i>Tango+</i> Monitor be powered from an uninterruptible power supply or a battery.
Power frequency (50/60 Hz) magnetic field IEC 61000-4-8	3 A/m		Power frequency magnetic fields should be at levels characteristic of a typical location in a typical commercial or hospital environment.
NOTE: U_T is the a.c. mains voltage prior to application of the test level			

In the event of a power loss to the monitor, all data and user settings are saved. The monitor will power-up with the same settings and data as prior to the power loss.

Immunity test	IEC 60601 test level	Compliance level	Electromagnetic environment-guidance
<p>Conducted RF IEC 61000-4-6</p> <p>Radiated RF IEC 61000-4-3</p>	<p>3 Vrms 150 kHz to 80 MHz</p> <p>3 V/m 80 MHz to 2.5 GHz</p>	<p>3V</p> <p>3V/m</p>	<p>Portable and mobile RF communications equipment should be used no closer to any part of the <i>Tango+</i>, including cables, than the recommended separation distance calculated from the equation applicable to the frequency of the transmitter.</p> <p>Recommended separation distance</p> $d = \left[\frac{3,5}{\sqrt{P}} \right] \sqrt{P}$ $d = \left[\frac{3,5}{E_1} \right] \sqrt{P} \quad 80 \text{ Mhz to } 800 \text{ Mhz}$ $d = \left[\frac{7}{E_1} \right] \sqrt{P} \quad 800 \text{ Mhz to } 2.5 \text{ GHz}$ <p>Where P is the maximum output power rating of the transmitter in watts (W) according to the transmitter manufacturer and d is the recommended separation distance in meters (m).</p> <p>Field strengths from fixed RF transmitters as determined by an electromagnetic site survey,^a should be less than the compliance level in each frequency.^b</p> <p>Interference may occur in the vicinity of equipment marked with the following symbol: </p>

Note 1: At 80 MHz and 800 MHz, the higher frequency range applies

Note 2: These guidelines may not apply in all situations. Electromagnetic propagation is affected by absorption and reflection from structures, objects and people.

^a Field strengths from fixed transmitters such as base stations for radio (cellular/cordless) telephones and land mobile radios, amateur radio, AM and FM radio broadcast and TV broadcast cannot be predicted theoretically with accuracy. To assess the electromagnetic environment due to fixed RF transmitters, an electromagnetic site survey should be considered. If the measured field strength in the location in which the *Tango+* is used exceeds the applicable RF compliance level above, the *Tango+* should be observed to verify normal operation. If abnormal performance is observed additional measures may be necessary such as reorienting or relocating the *Tango+*.

^b Over the frequency range 150kHz to 80 MHz, field strengths should be less than $[V_1] \text{ V/m}$.

Recommended separation distances between portable and mobile RF communications equipment and the Tango+

The *Tango+* is intended for use in an electromagnetic environment in which radiated RF disturbances are controlled. The customer or the user of the *Tango+* can help prevent electromagnetic interference by maintaining a minimum distance between portable and mobile RF communications equipment (transmitters) and the *Tango+* as recommended below, according to the maximum output power of the communications equipment.

Rated maximum output power of transmitter. Watts (W)	Separation distance according to frequency of transmitter meters (m)		
	150 kHz to 80 MHz $d = \left[\frac{3,5}{V_1} \right] \sqrt{P}$	80 MHz to 800 MHz $d = \left[\frac{3,5}{E_1} \right] \sqrt{P}$	800 MHz to 2,5 GHz $d = \left[\frac{7}{E_1} \right] \sqrt{P}$
0.01	0.12	0.12	0.23
0.1	0.38	0.38	0.73
1	1.2	1.2	2.3
10	3.8	3.8	7.3
100	12	12	23

Note 1: at 80 MHz and 800 MHz, the separation distance for the higher frequency range applies.

Note 2: These guidelines may not apply in all situations. Electromagnetic propagation is affected by absorption and reflection from structures, objects and people.

For transmitters rated at a maximum output power not listed above, the recommended separation distance d in meters (m) can be estimated using the equation applicable to the frequency of the transmitter, where P is the maximum output power rating of the transmitter in watts (W) according to the transmitter manufacturer.

Frequently Asked Questions (FAQ's)

Q. How do I set up the Tango+ monitor to work with my stress system?

- A. To setup the *Tango+* with your stress system, please visit the **Tango+ Interface Notes** on the *SunTech Medical* website at www.SunTechMed.com and select Customer Service ► Downloads and under the Products section, select *Tango+*. If your stress system is not listed, please contact us at 1-800-421-8626.

Q. The Tango+ displays a status message. What does it mean and what do I do?

- A. See the reference guide (that is attached to your *Tango+*) or the Advice and Troubleshooting section (pg. 34) for details on the Status Message and solution.

Q. The Tango+ monitor returns results of 0/0 after blood pressure measurements. What do I need to do to get a BP reading?

- A. There are certain noisy conditions where the *Tango+* cannot accurately measure BP. When the *Tango+* encounters these situations, it returns a reading of 0/0. Placement of the microphone attached to the cuff is critical for reliable operation of the *Tango+*. Follow the instructions in the Cuff Tutorial located on the *SunTech Medical* website at www.SunTechMed.com and select Products ► *Tango+* ► View Orbit-K Cuff Tutorial for correct microphone placement. Follow steps 1 and 2 in Conducting the Stress Test in the User's Guide to provide the best conditions to obtain a measurement.

Q. Can I use a heart rate or blood pressure simulator to test whether the Tango+ is working correctly with my stress system?

- A. You cannot use a heart rate or blood pressure simulator to test whether the *Tango+* is working with your stress system. The *Tango+* monitor requires that the ECG signal and the Korotkoff sounds, collected by the microphone in the cuff, originate from the same source, meaning the patient.

Q. I cannot clearly see the Tango+ display. How do I fix this?

- A. If you cannot clearly read *Tango+*, you can adjust the contrast of the display by following these steps:
1. When the Main Measurement View is displayed, press the SELECT button 2 times. This will bring up the MAIN MENU screen.
 2. Using the UP or DOWN arrows, highlight MONITOR SET UP and press the SELECT button.
 3. Using the UP or DOWN arrows, highlight CONTRAST and press the SELECT button.
 4. Using the UP or DOWN arrows, modify the contrast of the screen. When you are finished, and press the SELECT button to confirm the choice.
 5. Using the UP or DOWN arrows, select EXIT twice to return to the Main Measurement View.

Q. How do I clean the cuff after a stress test?

- A. To clean the cuff after a stress test, you can do either of the following:
- Remove the bladder and microphone from the shell. Machine wash the shell in warm water with a mild detergent (50-140°F or 10-60°C). Line dry the cuff.
 - Use a medical grade mild disinfectant on the cuff. Afterwards, line dry.

Service Centers

For customers in the Americas:

SunTech Medical, Inc.
Service Department
507 Airport Boulevard, Suite 117
Morrisville, NC 27560 USA
Tel: 919.654.2300
Fax: 919.654.2301

For customers in Europe, the Middle East, Africa, Asia, and the Pacific:

SunTech Medical, Ltd.
Service Department
Oakfield Industrial Estate
Eynsham, Oxfordshire OX29 4TS
United Kingdom
Tel: +44 (0) 1865.884.234
Fax: +44 (0) 1865.884.235

Specifications, Blood Pressure Measurement

Measurement:	<p>Auscultatory, using R-wave gating and k-sound analysis, during all static and active phases of stress testing. Systolic pressures correlate to a K-1 Korotkoff sound. Diastolic pressures correlate to K-5 Korotkoff sound.</p> <p>The device is designed to function in the presence of a normal ECG sinus rhythm. There are some physical conditions (i.e. Bundle Branch Block, Arrhythmias, Atrial Fibrillation, Ventricular Fibrillation, Pacemakers, etc) that may limit the ability of <i>Tango+</i> to obtain an accurate reading.</p>	
Range:	Pressure: Dia: 20-150 mmHg Sys: 50-280 mmHg	Heart Rate: 40-200 BPM (beats per minute)
Accuracy:	<p>Blood pressure measurements determined with this device are equivalent to those obtained by a trained observer using the cuff /stethoscope auscultation method, within the limits prescribed by the American National Standard, Manual, electronic or automated sphygmomanometers.</p>	
Conditions for Use:	<p>Operating: 10°C (50°F) to 40°C (104°F) Less than 95% RH non-condensing.</p> <p>Storage: -20°C (-4°F) to 50°C (122°F) Less than 95% RH non-condensing.</p> <p>The system might not meet its performance specifications if used or stored outside the specified temperature and humidity ranges listed above.</p>	
Power:	<p>External power supply, use only SunTech part number 19-0012-00. Input: 100-240 VAC @ 1.6A max, 50-60 Hz. Output +9VDC @ 5A IEC 320 type input connector.</p>	
Calibration:	<p>The accuracy of cuff -pressure transducers/indicators should be verified annually.</p>	
Safety Systems:	<p>Independent hardware over-pressure circuit and redundant software overpressure algorithm to limit cuff pressure to less than 300 mmHg (+20/-10mmHg). Independent hardware timing circuit and redundant software timer algorithm to limit the duration of a blood pressure cycle to less than 180 seconds.</p>	
Dimensions:	<p>Size: 22.8 cm x 15.9 cm x 9.7 cm (9.0" x 6.3" x 4.1") Weight: 1.2 Kg (42.6 oz)</p>	

Standards:	<p>UL60601-1, CAN/CSA C22.2 601-1 EN 60601-1, IEC 60601-2-30, IEC 60601-1-2 (EMC), IEC 60601-2-49, ISO 9919, AAMI SP10:2002 + A1:2003</p> <p>Meets EN 1060-1, Specification for non-invasive sphygmomanometers – Part 1: General requirements and EN 1060-3, Non-invasive sphygmomanometers – Part 3. Supplementary Requirements for Electro-Mechanical BP Measuring Systems.</p>
Classifications:	Equipment Classification: Class II; Mode of Operation: Continuous.

Specifications, Pulse Oximetry

Accuracy:	70 - 100% \pm 2 digits (\pm 1 Standard Deviation*).
-----------	--

* Standard Deviation is a statistical measure up to 32% of the readings may fall outside those limits.

Limited Warranty

SunTech Medical, Inc. provides to the original purchaser the following limited warranty from date of invoice.

All serialized monitors	24 months
Orbit-K Cuffs	6 months
Accessories, i.e. patient cables, disposables	90 days

SunTech Medical, Inc. warrants each instrument to be free from defects in material and workmanship. Liability under this warranty covers servicing of the instrument when returned from the customer's facility within the United States prepaid to the factory. *SunTech Medical, Inc.* will repair any component(s) or part(s) that it finds to be defective during the period of this limited warranty. Should a defect become apparent, the original purchaser should first notify *SunTech Medical, Inc.* of the suspected defect. The instrument should be carefully packaged and shipped prepaid to:

SunTech Medical, Inc.
Service Department
507 Airport Boulevard, Suite 117
Morrisville, NC 27560-8200 USA

Tel: + 1.919.654.2300
+ 1.800.421.8626
Fax: + 1.919.654.2301

OR *SunTech Medical, Ltd.*
Service Department
Oakfield Industrial Estate
Enysham, Oxfordshire OX29 4TS UK

Tel: +44 (0) 1865.884.234
Fax: +44 (0) 1865.884.235

The instrument will be repaired in the shortest possible time and returned prepaid by the same shipping method as received by the factory.

This limited warranty is void if the instrument has been damaged by accident, misuse, negligence, act of God or serviced by any person not authorized by *SunTech Medical, Inc.*

This limited warranty contains the entire obligation of *SunTech Medical, Inc.* and no other warranties expressed, implied or statutory are given. No representative or employee of *SunTech Medical, Inc.* is authorized to assume any further liability or grant any further warranties except as herein.

Index

A

Accessories	27
Interface Cables	29
Pulse Oximetry, Finger Application	27
Pulse Oximetry, SpO ₂	27

C

Copyright Information	4
------------------------------	----------

E

EMC Statement	38
----------------------	-----------

F

Front Display	13
Graph View	15
Main Measurement View	13

M

Main Menu	16
Alarms	19
End Test	19
Measurement Setup	17
Measurement Table	19
Monitor Setup	16
View	18

P

Proper Cuff Placement	20
Replace Microphone	22

S

Safety and Effectiveness	5
Indications for Use	5
User Responsibility	5
Specifications	44
BP Measurement	44
Pulse Oximetry	45

T

Tango+ Operation	23
Calibration	31
Cleaning	33
Cuffs	33
ECG Cables	33
Monitor	33
SpO ₂ Sensors	33
Disposal	32
Exercise Stress Test	25
Headphone Kit	24
Maintenance	31
Pulse Oximeter	32
Stat Mode	24
Taking BP Measurement	23

Tango+ Setup	7
Hardware Setup	7
Power Supply Labels	10
Rear Panel Connections	8
Stress Systems	11
Stress System Setup	12
Tango+ Rear Labels	9
Troubleshooting	34
FAQ's	42
Service Centers	43
Status Messages	34

W

Warnings	6
Warranty	46



SunTech Medical, Inc.
507 Airport Boulevard, Suite 117
Morrisville, NC 27560-8200 USA
Tel: + 1.919.654.2300
1.800.421.8626
Fax: + 1.919.654.2301

SunTech Medical, Ltd.
Oakfield Industrial Estate,
Eynsham, Oxfordshire OX29 4TS, UK
Tel: +44 (0) 1865.884.234
Fax: +44 (0) 1865.884.235



www.SunTechMed.com

SunTech Medical, Ltd.
Level 25, Bank of China Tower
1, Garden Road Central
Hong Kong
Tel: +852.2251.1949
Fax: +852.2251.1950



www.SunTechMed.com

www.SunTechMed.com part #80-0001-06 Rev. F / 11.10.08